

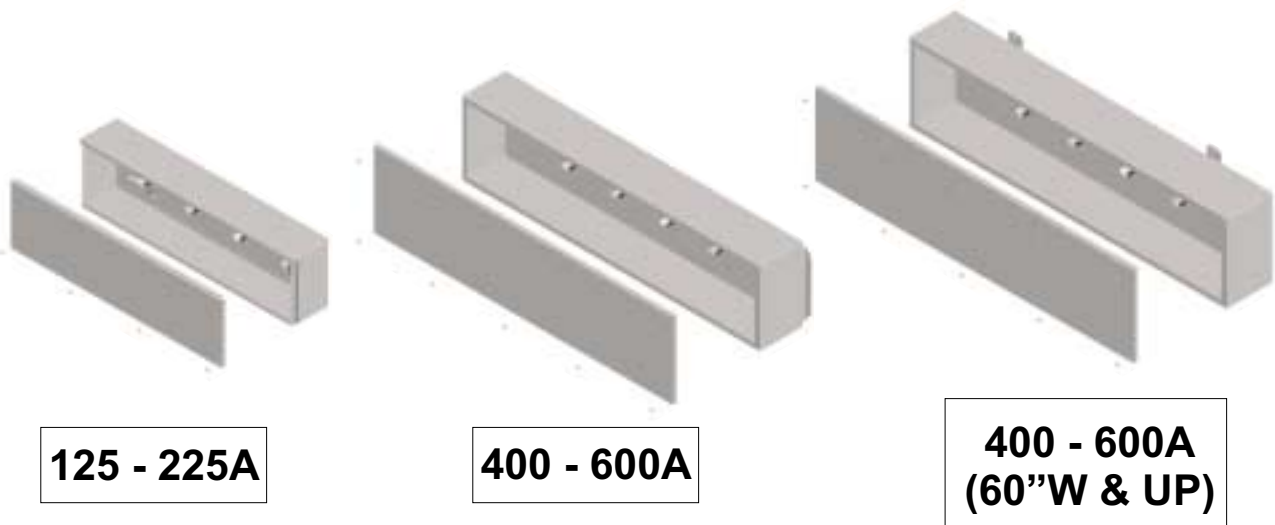

SPLITTER TROUGHS TYPE 3R (4 WIRE)

FEATURES AND BENEFITS

- EEMAC/CEMA 3R Type Enclosure (Weatherproof)
- Gasketed lift-off cover
- Cu/Al lugging with main and six secondaries
- Wall mounting
- Mild steel construction
- Industry standard ASA-61 grey industrial powder coat finish
- Custom sizes available (consult factory)



Model #	Amp	Mains	Secondaries	Description
3S-100-36-4W	125	#14 to 1/0	#14 to #2	36"H x 10"W x 6"D
3S-100-48-4W	125	#14 to 1/0	#14 to #2	48"H x 10"W x 6"D
3S-125-60-4W	125	#14 to 1/0	#14 to #2	60"H x 10"W x 6"D
3S-100-72-4W	125	#14 to 1/0	#14 to #2	72"H x 10"W x 6"D
3S-225-36-4W	225	#14 to 1/0	#6 to 3/0	36"H x 10"W x 6"D
3S-225-48-4W	225	#6 to 300 MCM	#6 to 3/0	48"H x 10"W x 6"D
3S-225-60-4W	225	#6 to 300 MCM	#6 to 3/0	60"H x 10"W x 6"D
3S-225-72-4W	225	#6 to 300 MCM	#6 to 3/0	72"H x 10"W x 6"D
3S-400-48-4W	400	(1) #4 to 600 MCM or (2) 1/0 to 250 MCM	#6 to 3/0	48"H x 10"W x 6"D
3S-400-60-4W	400	(1) #4 to 600 MCM or (2) 1/0 to 250 MCM	#6 to 3/0	60"H x 10"W x 6"D
3S-400-72-4W	400	(1) #4 to 600 MCM or (2) 1/0 to 250 MCM	#6 to 3/0	72"H x 10"W x 6"D
3S-600-48-4W	600	(2) #4 to 600 MCM	#6 to 3/0	48"H x 12"W x 7"D
3S-600-60-4W	600	(2) #4 to 600 MCM	#6 to 3/0	60"H x 12"W x 7"D
3S-600-72-4W	600	(2) #4 to 600 MCM	#6 to 3/0	72"H x 12"W x 7"D